

Vista lateral

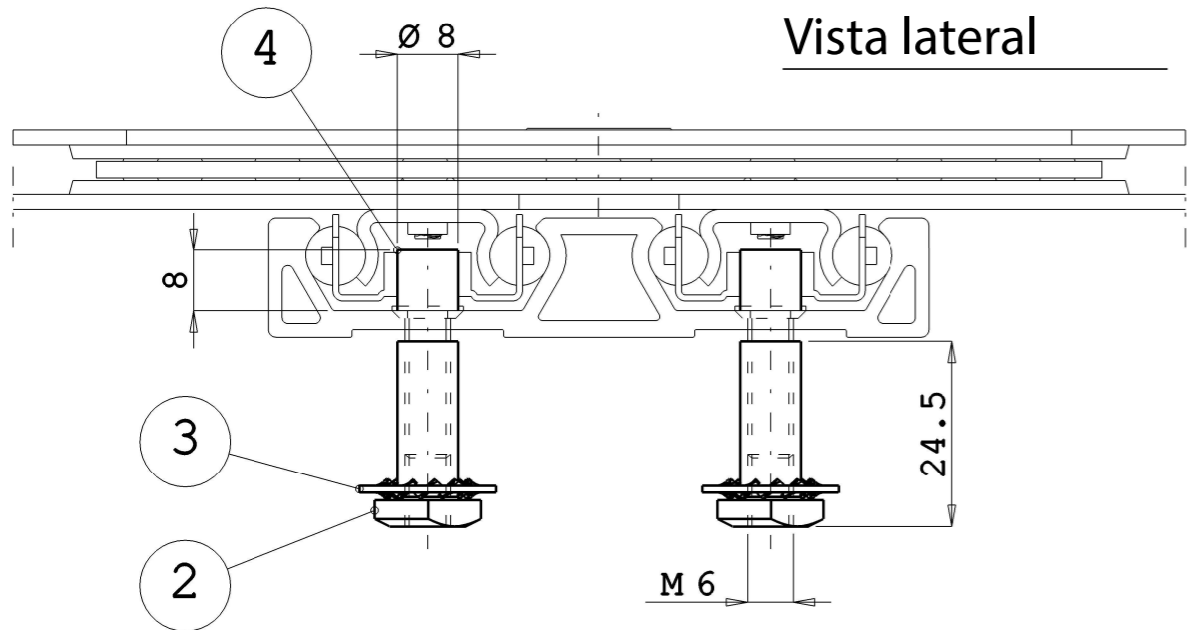

--	SCATOLA S0--	1
05	CHIAVE PER REGOLAZIONE	1
04	PERNO Ø8 LG.=8 MM.	4
03	ROND.DOPPIA DENTAT. Ø8.5	4
02	TUBETTO Ø14 LG.=24.5 MM.	4
01	GRP. EST. + GABBIE+ PIASTRA	1

	NOMBRE	FIRMA	FECHA	DESCRIPCIÓN:
DIBUJ.	AG		17/04/2024	KIT PERFIL LINE (COMPLETO)
VERIF.	AG			2 PERFILES DE 2,8M + HERRAJES
APROB.				
FABR.				
CALID.				Unidades envase: 1 unidad
				Unidades embalaje: 1 unidad
				www.verdustore.com

Contigo desde 1893

Verdú®

Código	Material	Acabado	Medida	A	
1050.101	acero	zincado	600	324	A4
1050.102	acero	zincado	700	386	

PESO: ESCALA:1:2 HOJA 1 DE 1

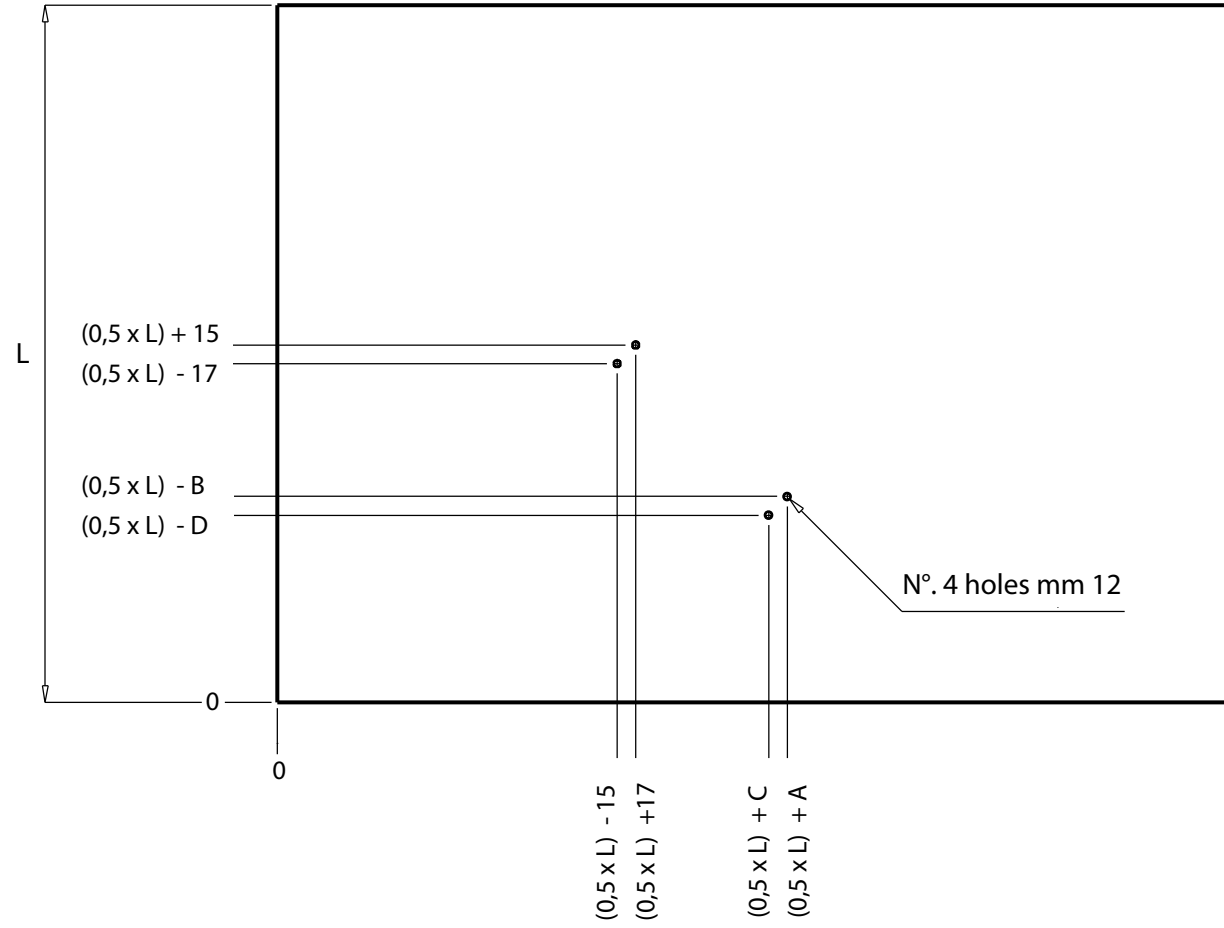

Dimensiones mínimas de corte en la parte fija de la placa rototraslante.
Profundidad máxima del corte mm 24

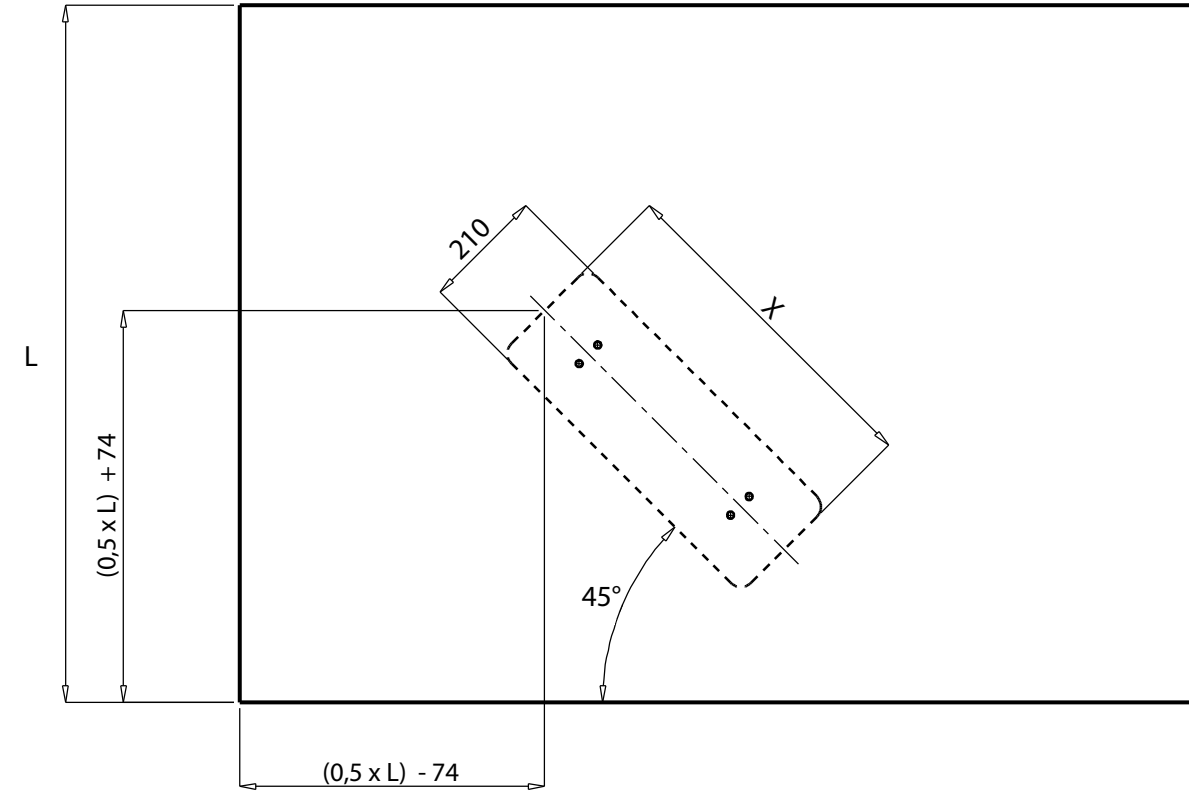

Dimensiones mínimas de corte en la parte fija de la placa rototraslante.
Profundidad máxima del corte mm 24

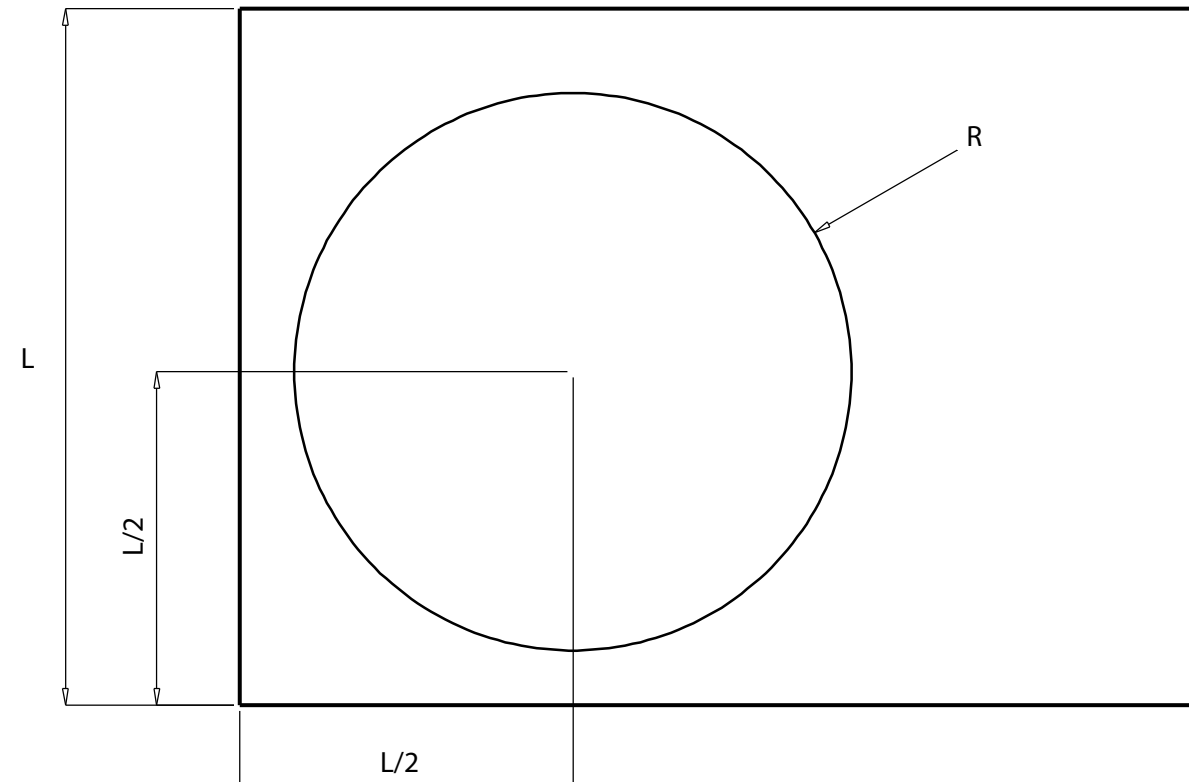

CODIGO	L	X	R	A	B	C	D
1050.101	from 600 to 699 mm	428	428	168	136	136	168
1050.102	from 700 to 900 mm	490	490	212	180	180	212