

All property rights and rights to exploitation of copyright for this drawing data remain ours; they may not be made available to third parties without our consent.

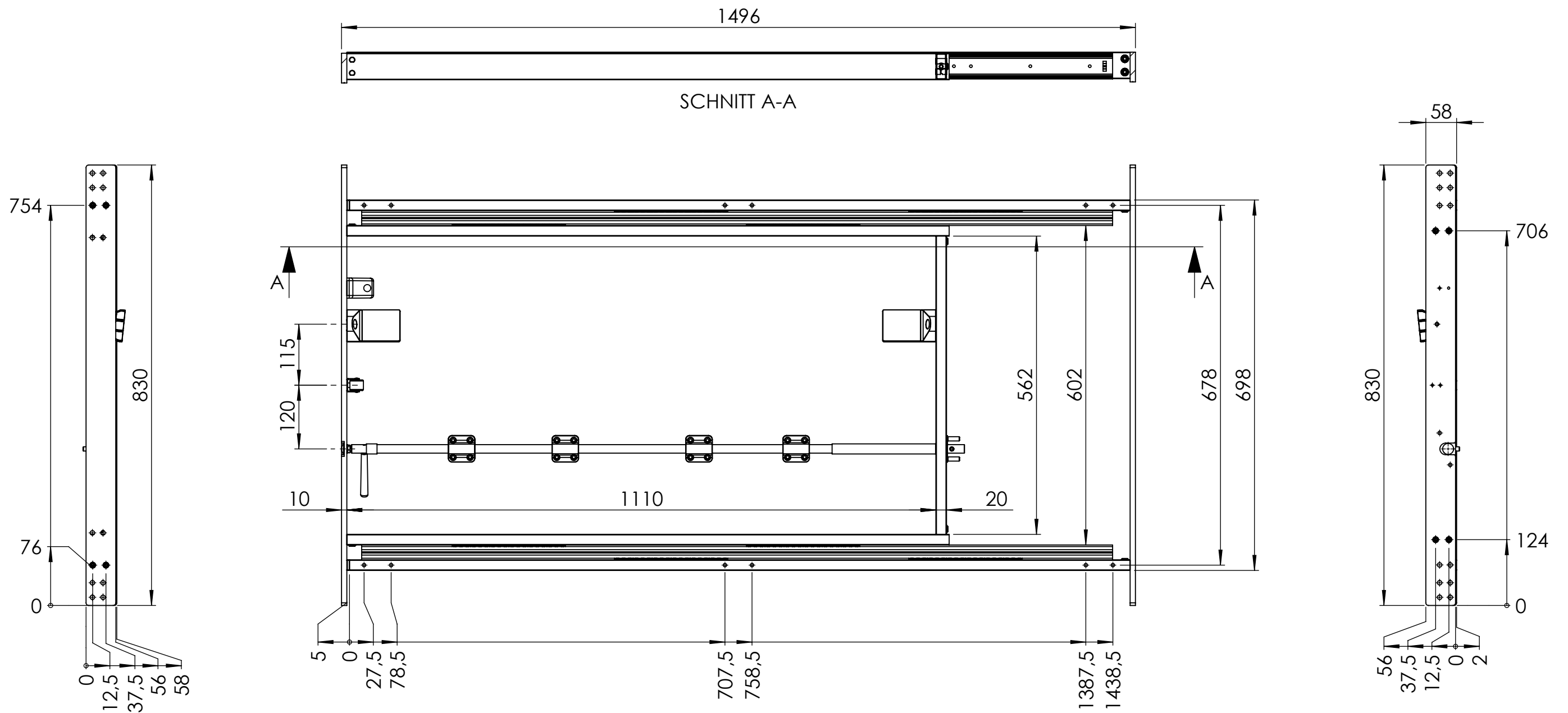

d	Update fitting of 15240	30.07.2021	G. Guzy
c	In AP und IP ZHP Ø5,4 Position angepasst	18.06.2021	A. W.
b	Auf neue Quergewindebolzen umgestellt	14.06.2021	A. W.
a	Frame von geschweißt auf geschraubt umgestellt	12.03.2020	A. W.

Index	Change	Date	Name
-------	--------	------	------

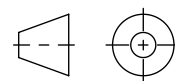

DIN ISO 128-30

Description:

FR/F-T2/SR/FM/1496x830x58

Surface:

Material:

Weight: 26.13 kg

PÖTTKER		Name	Date	Company
Transforming furniture		Signed A.Wewior	27.11.2019	Second Company:
		Tested G.Guzy	30.07.2021	

way of travel : ca. **1272** mm

General tolerance: DIN ISO 2768 - m	Item No: 16149101	Scale 1:8	Page 1/4	A3
-------------------------------------	--------------------------	-----------	----------	-----------

All property rights and rights to exploitation of copyright for this drawing data remain ours; they may not be made available to third parties without our consent.

CLOSE

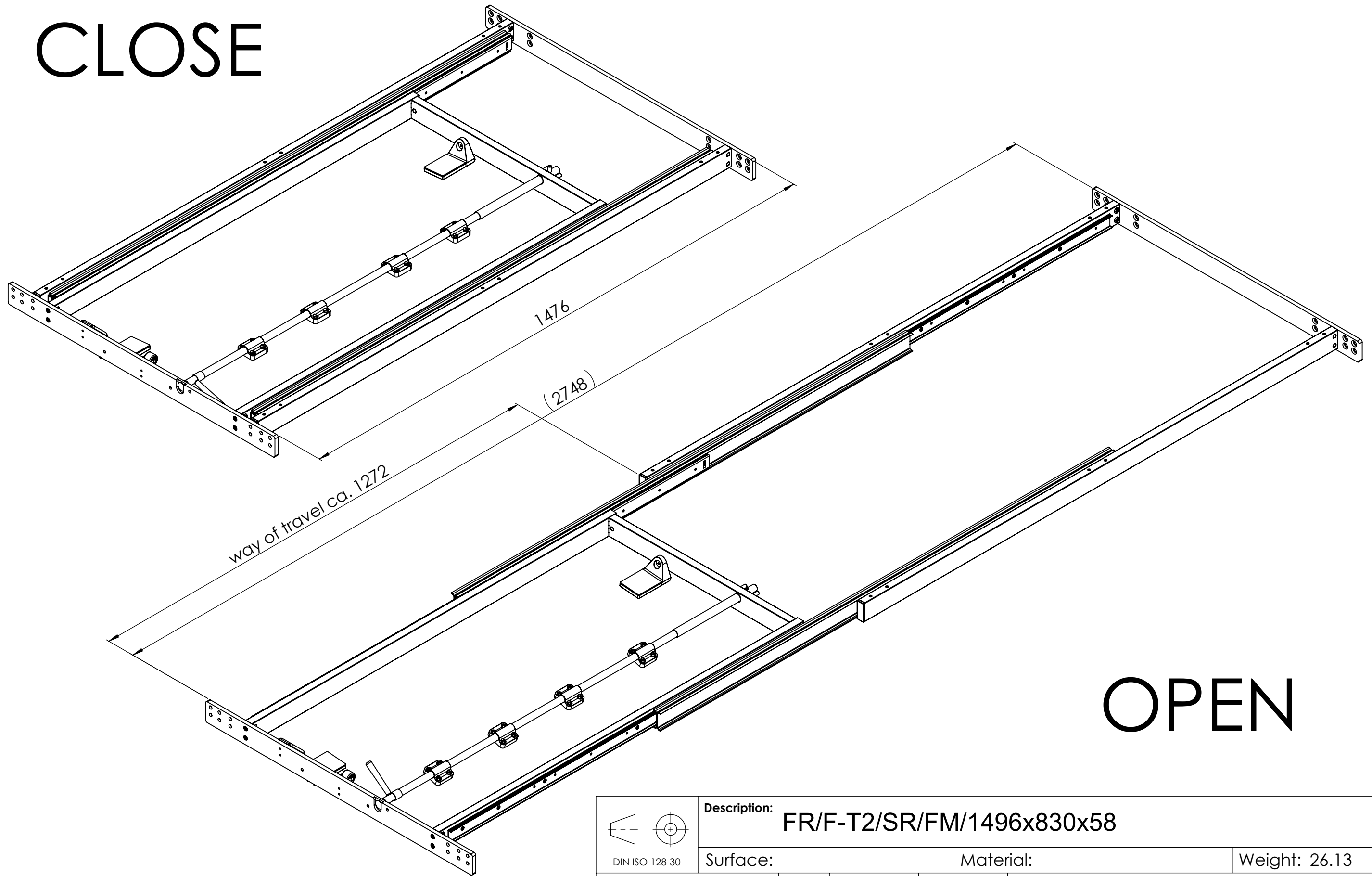

OPEN

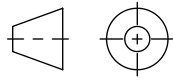
 DIN ISO 128-30	Description: FR/F-T2/SR/FM/1496x830x58					
	Surface:		Material:		Weight: 26.13 kg	
PÖTTKER Transforming furniture		Name	Date	Company		
	Signed	A.Wewior	27.11.2019			
	Tested	G.Guzy	30.07.2021	Second Company:		
General tolerance: DIN ISO 2768 - m		Item No:	16149101	Scale 1:8	Page 2/4	A3

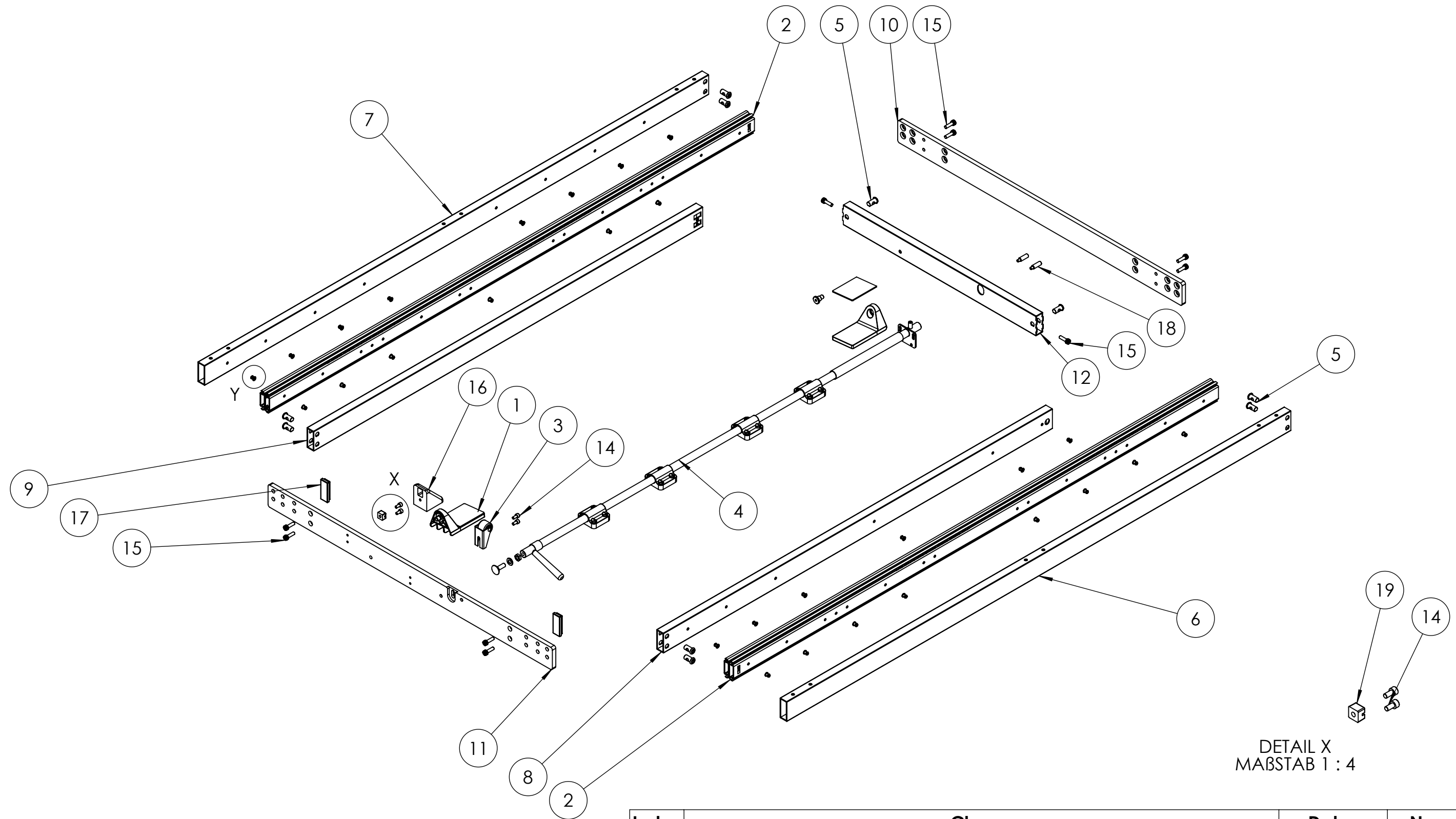

All property rights and rights to exploitation of copyright for this drawing data remain ours; they may not be made available to third parties without our consent.

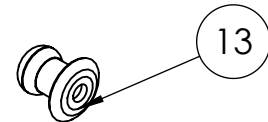

DETAIL Y
MABSTAB 1 : 1

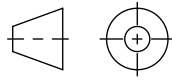

DETAIL X
MABSTAB 1 : 4

Index	Change			Date	Name
 DIN ISO 128-30	Description: FR/F-T2/SR/FM/1496x830x58				Weight: 26.13 kg
	Surface:		Material:		
 Transforming furniture	Name	Date	Company		
	Signed	A.Wewior	27.11.2019		
	Tested	G.Guzy	30.07.2021		
General tolerance: DIN ISO 2768 - m		Item No:	16149101	Scale 1:8	Page 3/4

All property rights and rights to exploitation of copyright for this drawing data remain ours; they may not be made available to third parties without our consent.

POS.	Item.No	Artikelbezeichnung	Menge
1	56990383	Set-Wippe/100x60x50/Kunststoff	2
2	47141303	F-T2/1415.4/1415.4/KK6-6	2
3	23990903	Kastenrolle für Tischbeine / Langloch	1
4	23115112	FM-Stop/Ø16x2x1159/1xFRS/4R+2A	1
5	16730	Quergewindebolzen/M6/Ø10x20/Sechskant	10
6	16147404	AP/ZHP/F-T2/50x20x1471/re.	1
7	16147403	AP/ZHP/F-T2/50x20x1471/li.	1
8	16113508	IP/ZHP/F-T2/50x20x1135/re.	1
9	16113507	IP/ZHP/F-T2/50x20x1135/li.	1
10	16083302	ET/F-T2/56x10x830	1
11	16083301	FT/F-T2/FM/56x10x830	1
12	16056308	MT/ZHP/F-T2/50x20x566	1
13	15961	Blindniet Flachrundkopf, Ø5x10-AL/St.(4,5-6,0)	28
14	15760	Zyl.-Schraube+Inbus, M5x10-DIN 912-vz	4
15	15499	Zyl.-Schraube+Inbus, M6x20-DIN 912-vz-gerändelt	10
16	15240	Schutzkappe/47er Profil/50,5x50x38/PP/schwarz	1
17	15060	Kunststoffstopfen 50x20x0,8-3mm	2
18	14085	E091/1/Bremsbolzen für FM/Sechskant-M5/Ø8x29,3	2
19	16078	Würfelstopp, 14x10x14/PA6.6-Plustek/klein_Schwarz	1

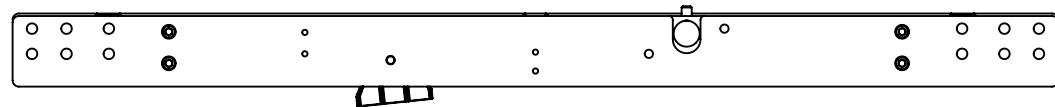

<p>DIN ISO 128-30</p>	Description: FR/F-T2/SR/FM/1496x830x58					
	Surface:		Material:		Weight: 26.13 kg	
<p>Transforming furniture</p>	Name	Date	Company			
	Signed	A.Wewior	27.11.2019			
	Tested	G.Guzy	30.07.2021	Second Company:		
General tolerance: DIN ISO 2768 - m		Item No:	16149101	Scale 1:6	Page 4/4	A3