

SECCIÓN B-B  
ESCALA 1 : 1

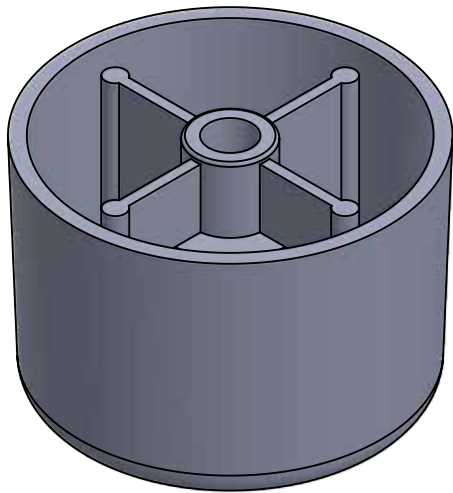

	NOMBRE	FIRMA	FECHA	DESCRIPCIÓN:
DIBUJ.	AG		04/06/2026	Pata H40 D55 ALON
VERIF.	AG			
APROB.				
FABR.				
CALID.				Unidades envase: 1 unidad
				Unidades embalaje: 400 unidades
<a href="http://www.verdustore.com">www.verdustore.com</a>				PESO: 0,0250kg

<b>VERDÚ</b>		
Código	Material	Acabado
03170019	plástico	negro
ESCALA: 1:2		HOJA 1 DE 1

A

A

4

3

2

1

F

F

E

E

D

D

C

C

B

B