

ARKORA Compás resorte a gas ascendente para puertas de madera y aluminio

*Arkora*  
*Ascendente*  
by ALK®

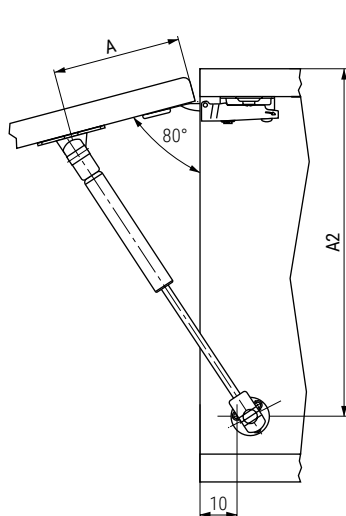

L	A	A2
164	55	190
247	100	260
355	150	365

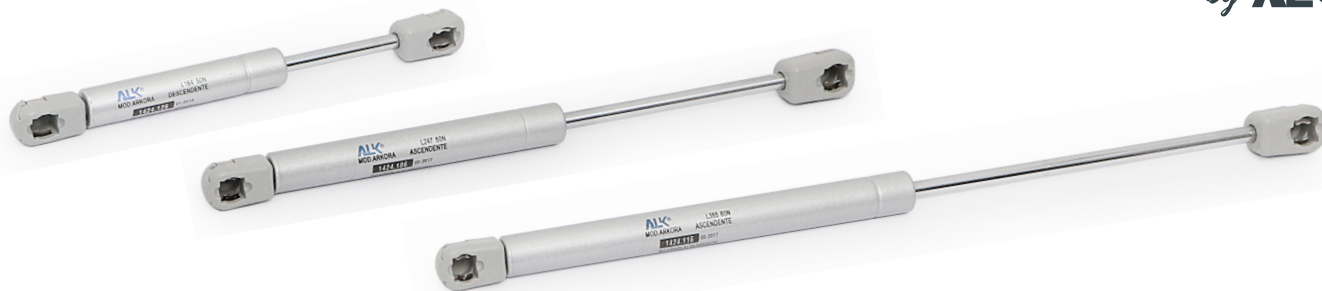
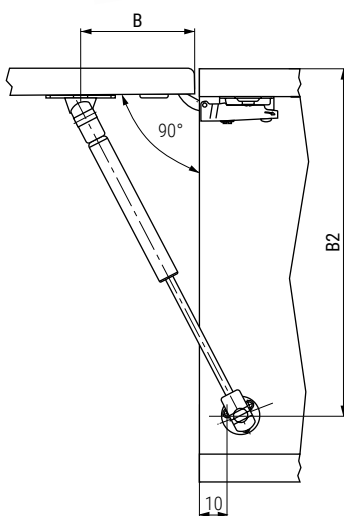

L	B	B2
164	45	185
247	90	255
355	140	360

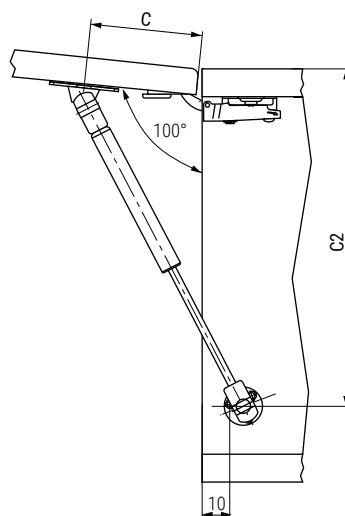

L	C	C2
164	40	180
247	80	250
355	130	355

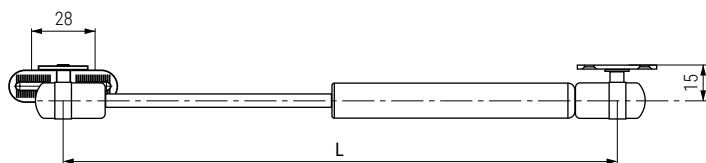
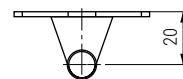
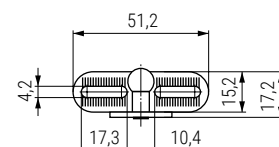
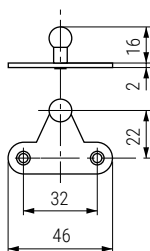
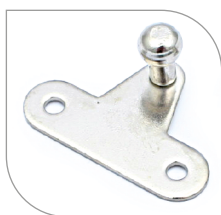
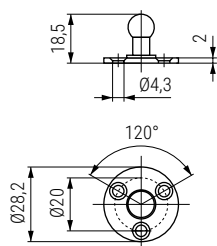
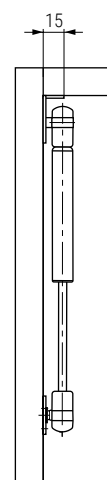

• FUERZA "N" = Potencia de extensión.

- Con los tres enganches para puertas de madera y aluminio incluidos.
- Con mecanismos de enganche rápido "CLIP-ON".
- Se acompañan instrucciones de montaje por cada compás.
- Se recomienda hacer pruebas técnicas.

164/247/355

CÓDIGO			Fuerza	Material	Acabado	📦
L=164	L=247	L=355				
1424.101	-	-	50N	acero	plata	20
-	1424.106	1424.116	60N	acero	plata	20
1424.102	1424.107	1424.117	80N	acero	plata	20
-	1424.108	1424.118	100N	acero	plata	20
-	1424.109	1424.119	120N	acero	plata	20
-	1424.110	-	150N	acero	plata	20
-	1424.111	-	200N	acero	plata	20

### Información y Complementos necesarios



Cód. 644.260



Cód. 644.411



Cód. 504.411



Ficha técnica