

### CALIBRO Sistema de enganche excéntrico Ø35mm. Doble espiral

Calibro  
by ALK®



- Con hexágono para llave de 6mm.
- Ajuste rápido y fuerte, máximo 3/4 de vuelta, 270° (menos de 1 vuelta).

CÓDIGO	Material	Acabado	
428.11	zamak	bruto	500

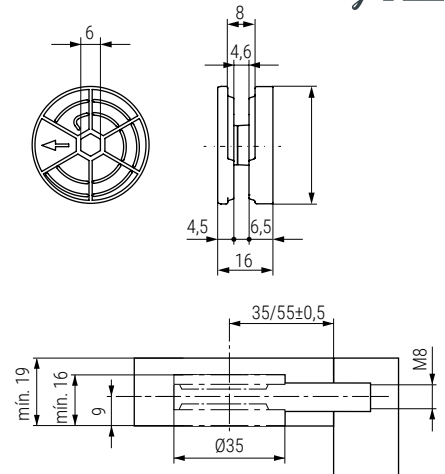

### Tirante M8

ALK®

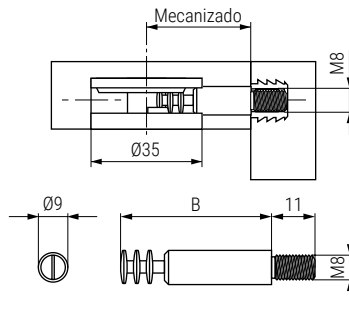
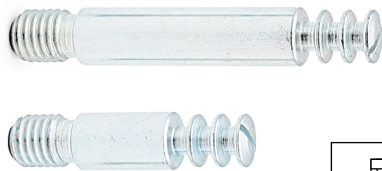

- Para ver tuercas consultar en el grupo 4.

CÓDIGO	Mecanizado	B	Material	Acabado	
428.32	35	29	acero	zincado	500
428.3	55	48	acero	zincado	500
428.13	57	49,5	acero	zincado	500

### Tirante 90° 50/50mm.

ALK®

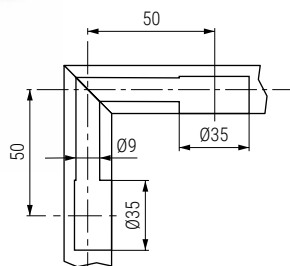

CÓDIGO	Material	Acabado	
428.8	acero	zincado	500

### Tirante doble para unión de tableros

ALK®



cód. 428.9

cód. 428.4

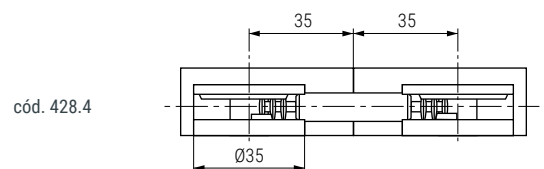

cód. 428.4

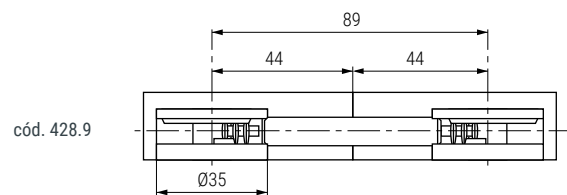

cód. 428.9

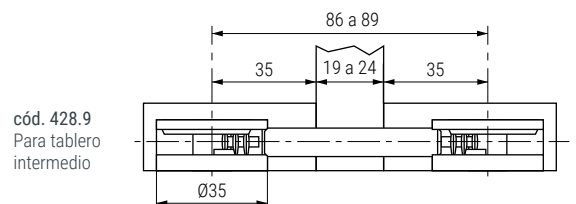

cód. 428.9  
Para tablero  
intermedio

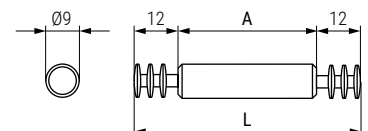

CÓDIGO	L	A	Material	Acabado	
428.4	55	31	acero	zincado	500
428.9	74	50	acero	zincado	250